

pci
Journal
prestressed concrete institute

Special Report

**Cable Stayed Bridges
With Prestressed Concrete**

by

Fritz Leonhardt

Prof. Dr. Ing.
Consulting Engineer
Stuttgart
West Germany

Cable Stayed Bridges With Prestressed Concrete



Fritz Leonhardt

Prof. Dr. Ing.
Consulting Engineer
Stuttgart
West Germany

The number of cable stayed bridges with concrete or steel has increased dramatically during the last decade. Ref. 1 presents a survey of some 200 cable stayed bridges that have been designed or built throughout the world.

Although most of these bridges are made of steel, many of them could have been designed with prestressed concrete. In fact, by using this material, the design, structural detailing and construction method can be simplified, thus producing a bridge that is economically and aesthetically superior.

Unfortunately, there are many bridge engineers today that do not fully under-

stand the basic principles of cable stay bridge design and construction. The purpose of this article is to present the latest state of the art on cable stayed bridges while elaborating upon the fundamentals and possibilities pertaining to such structures. The text will cover highway, pedestrian and railroad bridges using prestressed concrete.

1. Range of Feasibility of Cable Stayed Bridges

There are some misconceptions regarding the range of feasibility of cable stayed bridges. For example, the statement is often made that cable stayed bridges are suitable only for spans from 100 to 400 in (about 300 to 1300 ft). This statement is wrong. Pedestrian bridges with only about 40 in (130 ft) span can be built to be structurally efficient and cost-

Note: This paper is based upon the Keynote Lecture presented by the author at the FIP Congress in New Delhi, India. February 16, 1986, and a similar lecture, including steel bridges, at the Symposium on Strait Crossings in Stavanger, Norway, in October 1986.

Based on his more than 50 years of experience as a consulting engineer on specialized structures, the author presents a state of the art report on prestressed concrete cable stayed bridges with authoritative advice on the design-construction intricacies involved with such structures.

effective. Employing prestressed concrete, the superstructure can be made very slender using a few cable stays and a deck with a depth of only 25 to 30 cm (10 to 12 in.).

Highway bridges can be built of prestressed concrete with spans up to 700 in (2295 ft) and railroad bridges up to about 400 in (1311 ft). If composite action between the steel girders and a concrete deck slab is utilized, then spans of about 1000 and 600 in (3279 and 1967 ft) for highway and railroad bridges, respectively, can be attained safely.

For the crossing of the Messina Straits in Italy (see Fig.1), our firm designed an all-steel cable stayed bridge with a main span of 1800 in (5900 ft) for six lanes of road traffic and two railway tracks without encountering any structural or construction difficulties.

Many bridge engineers believe that for spans above 400 in (1311 ft), a suspension bridge is preferable. This assumption is false. In fact, a cable stayed bridge is much more economical, stiffer and aerodynamically safer than a comparative suspension bridge. The author

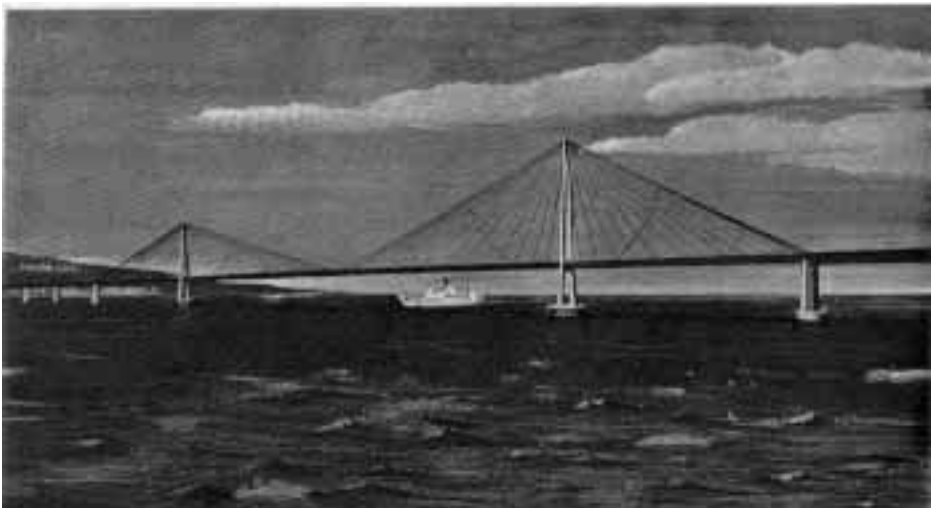

Fig. 1. Messina Straits Bridge, linking Sicily and Italian peninsula; design by Gruppo Lambertini (1982).

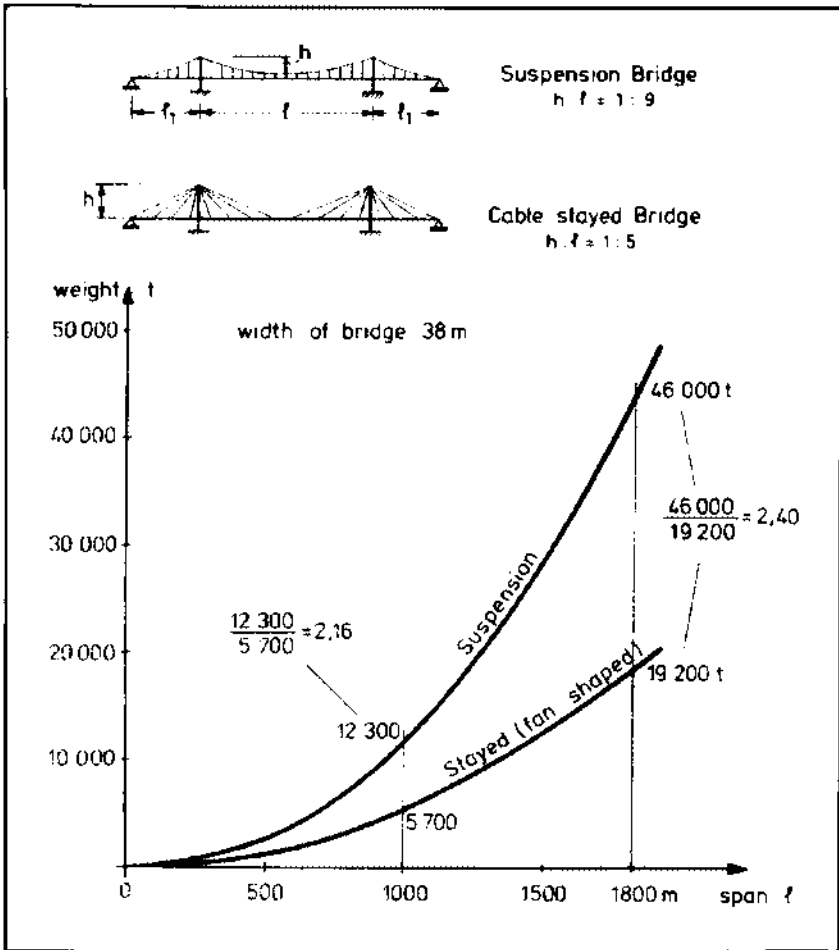

Fig. 2. Comparison of quantity of cable steel for suspension bridges and cable stayed bridges.

showed this was true as early as 1972!

In designing a cable stayed bridge there is first the problem of finding the required quantity of high strength steel for the cables. For a bridge with a 1800 m (5902 ft) main span and 38 m (125 ft) width, a suspension bridge needs 46000 t (50700 tons) of steel whereas a cable stayed bridge only needs 19200 t (21170 tons) of steel (see Fig. 2). In the latter case this represents only about 40 percent the amount of steel.

Furthermore, a suspension bridge needs a stiffening girder with a bending stiffness

which must be about ten times larger than that of the cable stayed bridge. The suspension bridge needs additional heavy anchor blocks which can be extremely costly if the navigation clearance is high and foundation conditions are poor. The total cost of such a suspension bridge can easily be 20 to 30 percent above the costs of a cable stayed bridge.

Currently, the second Nagoya Harbour Bridge (in Japan), at 600 m (1967 ft), has the longest span of a cable stayed bridge in steel. This structure, which was designed by Dr. Ing. Kunio Hoshino (a



Fig. 3. Nagoya Harbour Bridge, Japan.

former student of the author), is now under construction. When completed, it will look similar to the first Nagoya Harbour Bridge (see Fig.3). The author is confident that in the near future similar such spans will be built using prestressed concrete.

Range of span is only one important parameter in designing cable stayed bridges. Special situations such as curved spans and skew crossings can be easily solved using stays.

The engineer can choose between a large variety of configurations: symmetrical spans with two towers, unsymmetrical spans suspended from one tower, or multi-spans with several towers in between. This is an ideal field for creativeness in design to satisfy the functional requirements of the project and to obtain an aesthetically pleasing structure which complements the environment.

2. The Main Girder System

2.1 Development of multi-stay cable system

Some of the first cable stayed bridges (like the Maracaibo Bridge) had only one

cable at each tower (see Fig.4), leaving long spans requiring a beam with large bending capacity. Soon three to five cables were used, decreasing the bending moments of the beam and the individual cable forces to be anchored. However, structural detailing and construction procedures were still difficult.

The desired simplification was obtained by spacing the cables so closely that single cables with single anchor heads were sufficient which could easily be placed and anchored. The spacing became only 4 to 12 in (13 to 39 ft), allowing free cantilever erection without auxiliary cables. Simultaneously, the bending moments became very small, if an extremely small depth of the longitudinal edge beams and very stiff cables were chosen.

This multi-stay cable system can no longer be defined as a beam girder. Rather, it is a large triangular truss with the deck structure acting as the compressive chord member. The depth of the longitudinal beams in the deck structure is almost independent of the main span, but it must be stiff enough to limit local deformations under concentrated live load and to prevent buckling due to the large compressive forces created by the inclined cables.

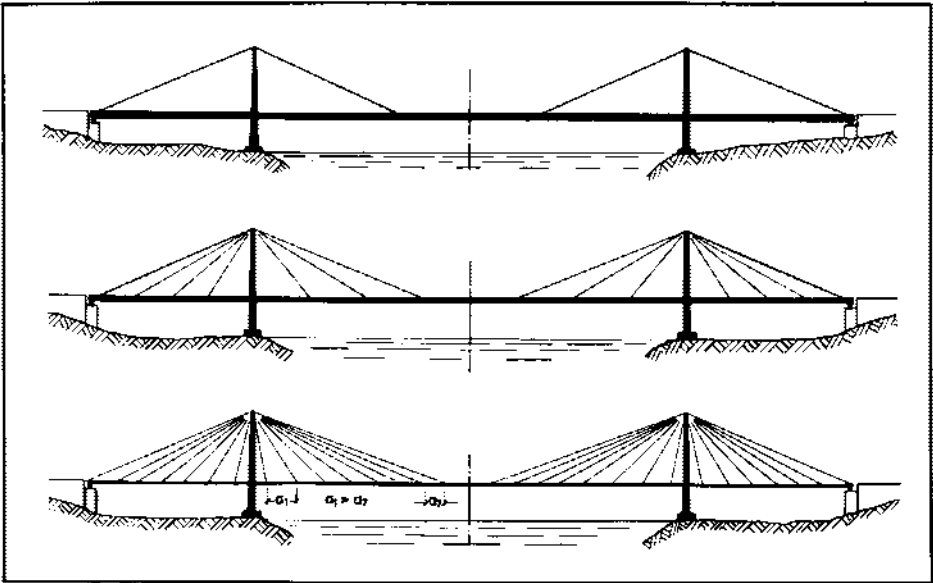

Fig. 4. Development of structure to multi-stay cable bridge. Note that additional cables allow beam of superstructure to be progressively more slender.

The stiffness of this new system depends mainly on the angle of inclination and on the stress level of the cables. Fig. 5 shows the enormous influence of the stress in such cables on the effective modulus of elasticity. Low stresses give a large sag and low stiffness. The stress in the cables should be at least 500 to 600 N/MM² (72500 to 87000 psi). For long spans, stiffening ropes (as shown in Fig. 6) are needed to prevent an excessive change of sag. The simplification of the structural design and of the erection process gained by this multi-stay cable system should be used whenever suitable.

2.2 Arrangement of stay cables

If all the cables are anchored at the top of the tower, the structural system is called a fan-shaped configuration (see Fig.7). Unfortunately, the concentration of the anchorages causes structural difficulties when the number of cables is large. Therefore, it is preferable to distribute the

anchorages over a certain length of the tower head and get a semi-fan arrangement (as shown in Fig.8), which also improves the appearance of the bridge.

In the author's early bridges across the Rhine River in Dusseldorf, the architect wanted to have all the cables parallel and the anchorages equally distributed over the height of the tower. This is called the harp-shaped arrangement (see Fig. 9). The system requires more steel for the cables, gives more compression in the deck and produces bending moments in the tower. However, the structure is aesthetically pleasing, especially when looking at the bridge under a skew angle. Dr. Ulrich Finsterwalder, the world renowned bridge engineer, prefers this harp arrangement with many closely spaced cables. Such a scheme was chosen for the Dame Point Bridge in Florida (see Fig.10), with a main span of 396 m (1298 ft), which is now under construction.

In these multi-stay bridges, the deck is hung up with cables near the tower

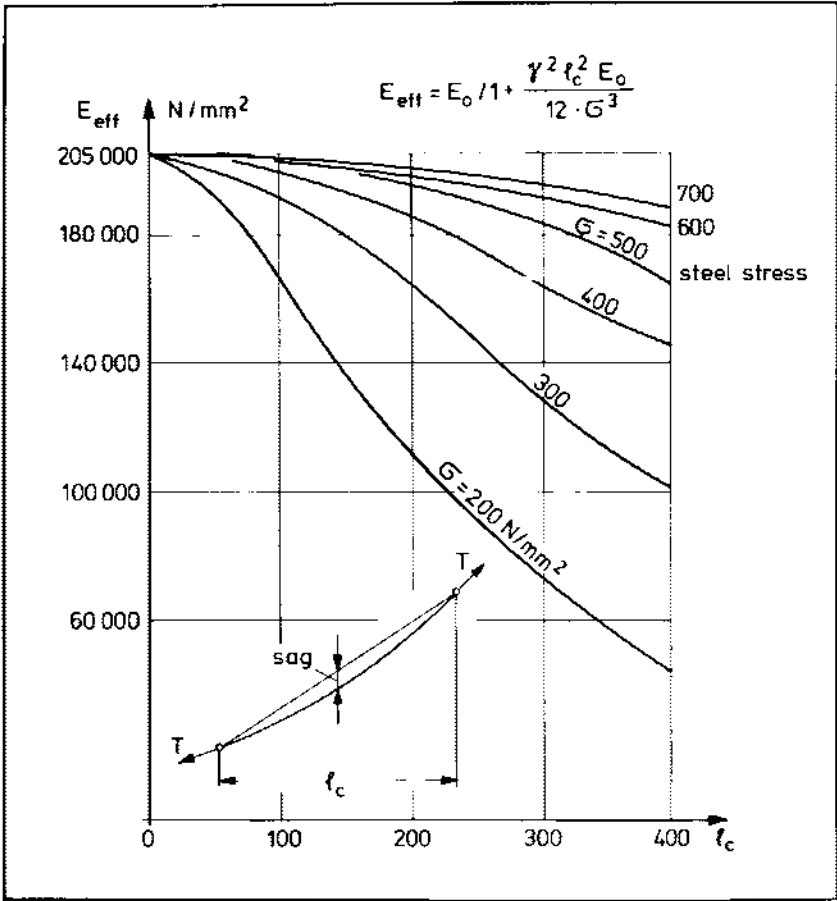

Fig. 5. Effective modulus of elasticity depends primarily on steel stress in cable which in turn affects the cable sag.

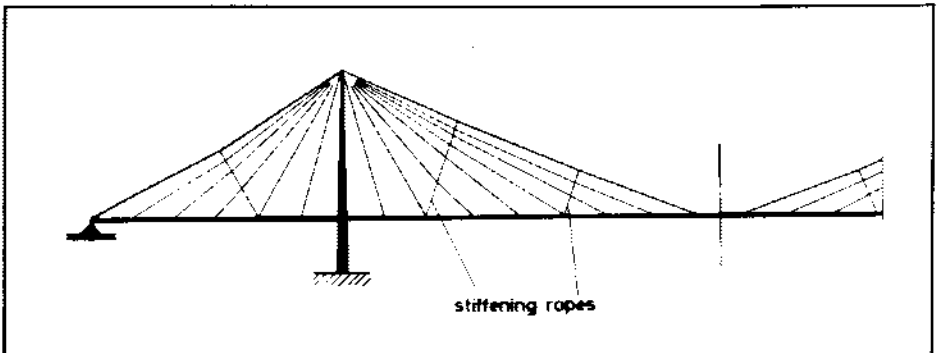

Fig. 6. Stiffening ropes affixed to long cables reduce cable sag.

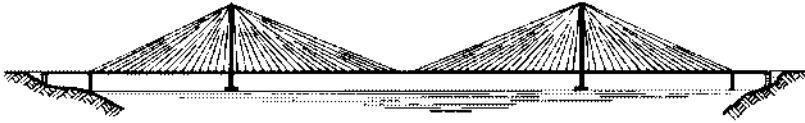

Fig. 7. Fan shape arrangement of cables.

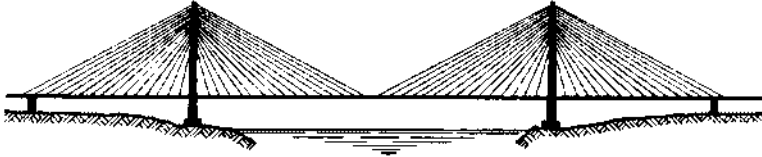

Fig. 8. Semi-fan arrangement of cables.

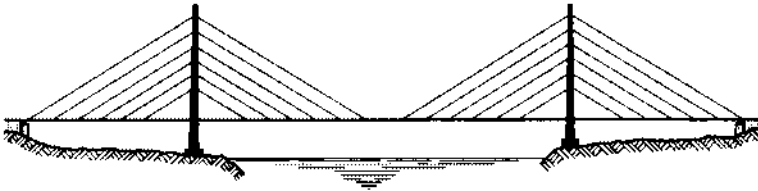

Fig. 9. Harp shape arrangement of cables.

also, to avoid a stiff bearing at the tower. This could cause very large negative bending moments which might be unacceptable for the small depth of deck girder used.

Normally, the bridge is supported by cables in two planes along the edges of the deck. In some cases (mainly for medium spans), cables in one plane are used along the centerline of the deck. A box girder with sufficient torsional rigidity is then needed which requires some depth so that it can also resist the large bending moments. Such a girder must be supported at the tower to resist torsion and as a consequence the cables can begin at a certain distance from the tower, leaving a "window" in the cable net open. The Brotonne Bridge in France is such an

example (see Fig.11).

Of course, other cable configurations are possible, depending on local conditions, like very short side spans. A harmonic arrangement of cables is important for good appearance and it should be chosen with care and diligence.

2.3 Ratio between main and side spans

The ratio between side span l_1 and main span l has an important influence on the stress changes in the back stay cables which holds the tower back to the anchor pier. Live load in the main span increases these stresses whereas live load in the side span decreases them. These stress changes must be kept safely below the

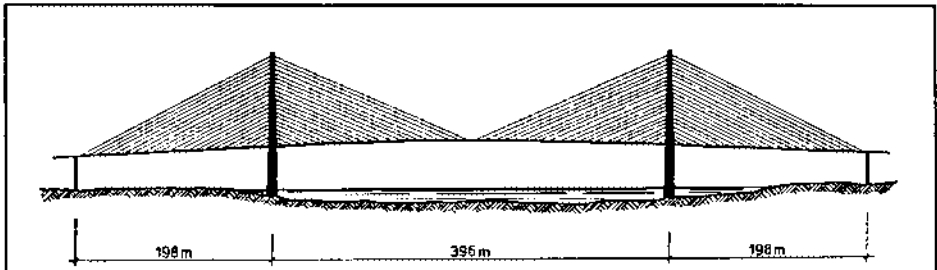

Fig. 10. Dame Point Bridge across St. John's River, Florida, with central expansion joint; design by Ulrich Finsterwalder.

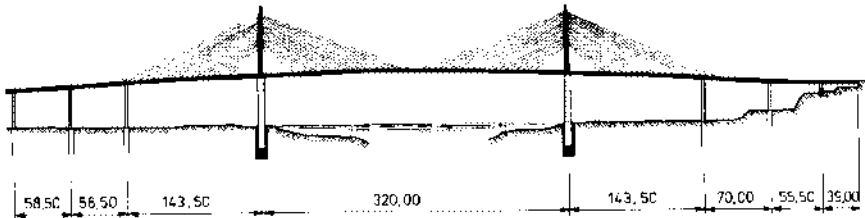

Fig. 11. Semi-fan arrangement of cables leaving a "window" open near the tower; Brotonne Bridge, France.

fatigue strength of the cables. This fatigue strength is a criterion for the allowable ratio l_1/l , which depends mainly on the relation between live and dead load, p to g .

Prestressed concrete bridges allow longer side spans than steel bridges. The author has published charts in a state of the art report for IABSE (1980) from which suitable ratios can be read. For concrete highway bridges l_1/l can be about 0.42; for railway bridges the ratio should not be larger than 0.34. The ratio decreases with the span length. The magnitude of the anchorage forces at the anchor pier also depends on the ratio l_1/l . In particular, short side spans give large anchorage forces.

If there is no need for large free side spans, then a rather heavy continuous beam bridge with spans of about 40 m (131 ft) can be used as a long anchorage zone in which all cables act as back stays

and concentrated vertical anchorage forces can be avoided (see Fig.12). This solution is especially advantageous if a very long span is hung up to one tower.

If only a short or even no side span is practical, then the back stay cables can be ground anchored over a certain length or even be joined in an anchor block. This has been done for the C. F. Casados Bridges in Spain, the Barrios de Luna Crossing (see Fig.13) which at 440 m (1443 ft) is currently the longest span of prestressed concrete, and the Ebro Bridge (see Fig.14) which has an inclined tower and back stay cables spreading sidewise into two planes, giving a most interesting impression from the highway.

The inclination of the tower backwards makes the main cables longer, the back-stay cables shorter and steeper. There is no technical or economical advantage in this but a more thrilling appearance. A

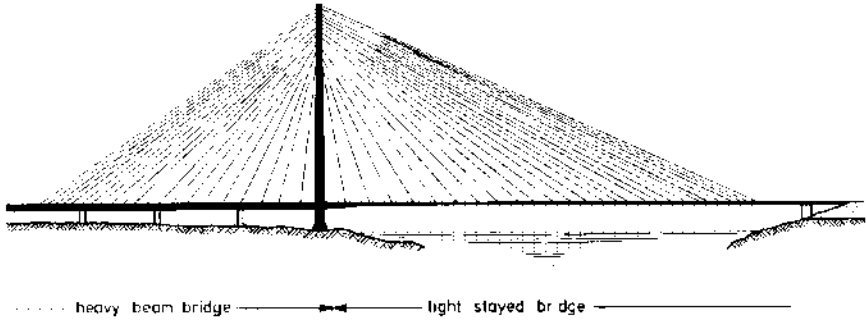

Fig. 12. Heavy beam bridge used as anchor zone for back stay cables.

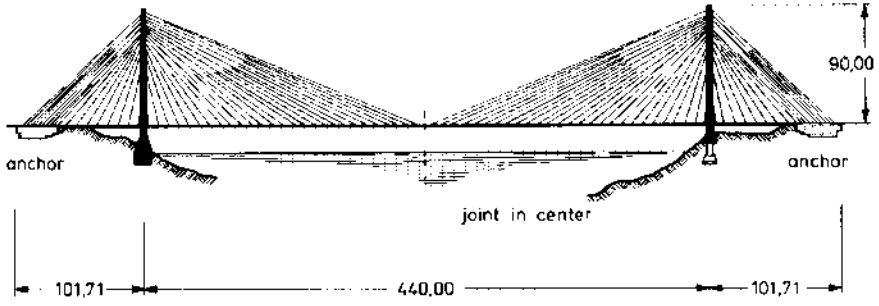

Fig. 13. Back stay cables anchored in ground; Barrios de Luna Bridge, Spain.

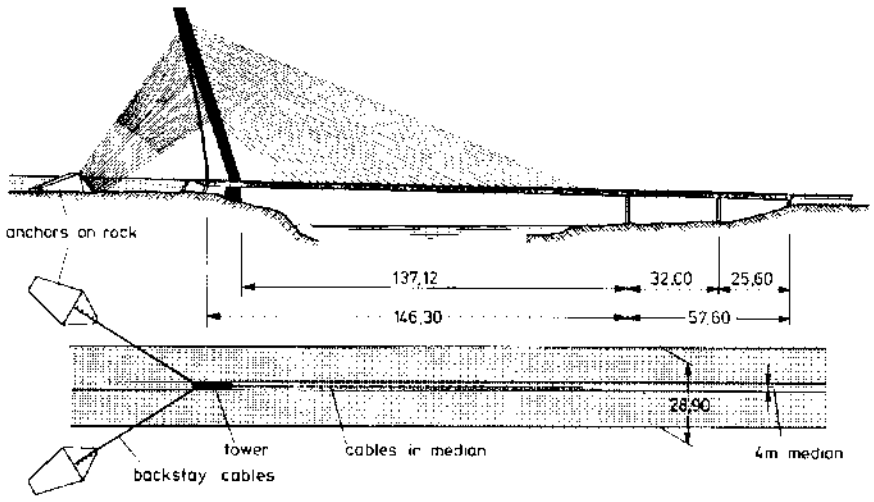

Fig. 14. Back stay cables spread sideways; Ebro Bridge, Spain.

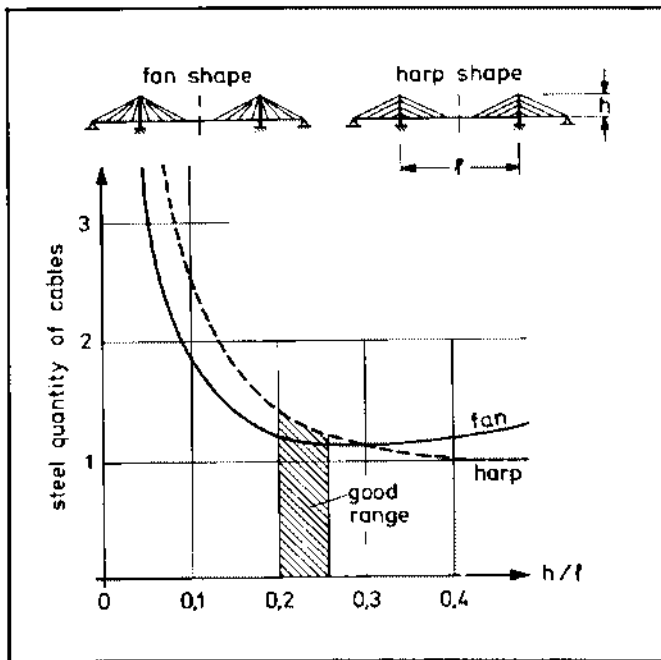

Fig. 15. Quantity of cable steel as a function of relative height of towers.

forward inclination of the tower towards the main span produces uneasy and uncomfortable feelings. Towers should normally be vertical.

3. Optimal Height, Shape and Stiffness of the Towers

The cable forces and the required quantity of cable steel decrease with the height of the tower above the road level (see Fig.15). A good range is between $0.2l$ and $0.25l$. For bridges with only one tower the height must be related to about 1.81. Towers of cable stayed bridges must be higher than those for suspension bridges which usually have $h/l = 0.10$.

The height of the tower also defines the angle of inclination of the longest cables. This angle should not be smaller than about 25 degrees because otherwise the deflections will become too large.

In the longitudinal direction the towers

should be slender and have a small bending stiffness, in order to avoid large bending moments to be reacted by the foundations. If the soil conditions are poor, then towers can even be hinged at the foot and fixed only during erection. The towers of some of the author's Rhine River bridges have such foot hinges. Towers should be built of concrete because concrete towers are much cheaper than steel towers.

The shape of the towers can be very simple. Even for large spans up to 500 in (1640 ft), free standing tower legs may be sufficient if they are fixed and transversely connected in the foundation only [see for example the Kniebrücke in Dusseldorf (Fig.16)]. No transverse bracing is needed if the cables are in a vertical plane and if the cross section of the tower is unsymmetrical with most of the load carrying area close to the bridge deck (see Fig.17). This arrangement brings the center of gravity close to the plane of the cables and still gives much transverse bending stiff-



Fig. 16. The slender free standing towes of Kniebrücke in Düsseldorf, West Germany.

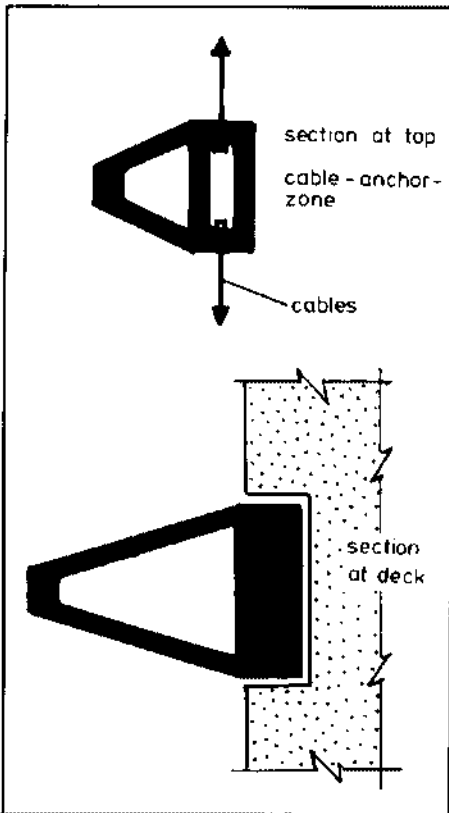

Fig. 17. Efficient cross section for free standing towers.

ness to carry the wind reactions to the foundation. Such tower legs should be tapered in both directions. Modern climbing forms allow this tapering without much extra cost.

The bridge deck with the railings should run clear through the tower legs and the cable anchorages should be close to the railings; therefore, very slender tower shafts become desirable. If the semi-fan cable arrangement is used, then one or two transverse bracings between the tower legs are suitable (see Fig.18). The bracing above the road level should be slender and look light between the thin cables.

For very long spans and especially in regions with strong wind forces, the A-shaped tower is the optimal solution for appearance and wind stability (see Fig.19). In high level bridges, the tower legs can be joined under the deck level in order to combine the foundations. The Farb Bridge in Denmark was designed in such a way. These A-shaped towers with the cables sheltering the highway give a feeling of safety to the motorist and an exciting and pleasing view (see Fig. 20).

Fig. 18. Tower shapes for two planes of cables.

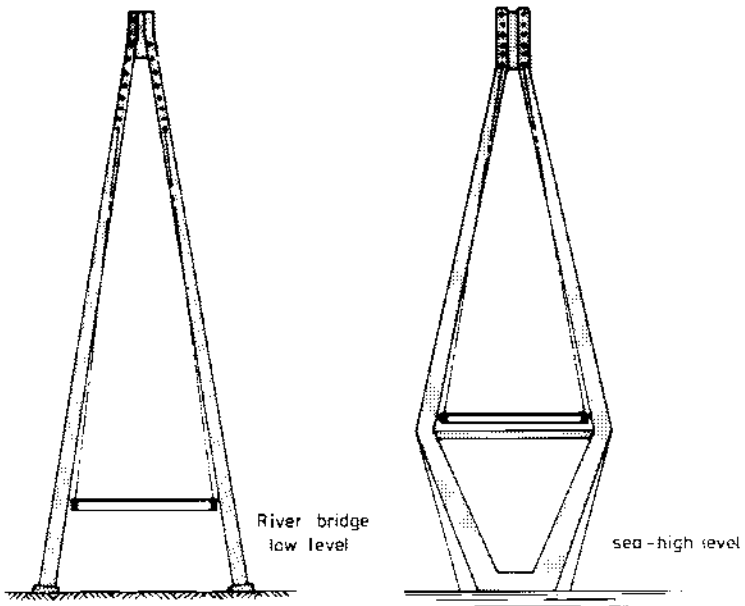
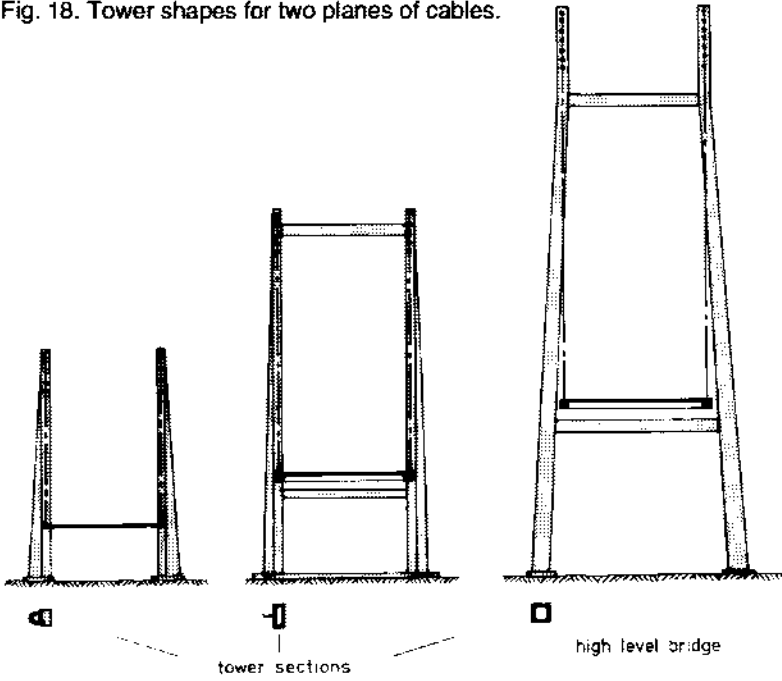

Fig. 19. A-shaped towers for two cable planes.



Fig. 20. View of A-shaped tower as motorist approaches bridge. There is an inherent feeling of comfort and safety.

For bridges with cables in one plane it is best to design a slender single tower in the median strip and to protect the cables and the tower with strong guardrails (see Fig. 21) as was done for the Rhine Bridge in Bonn, the Brotonne Bridge in France, the Sunshine Skyway Bridge in Tampa, Florida and other bridges. Tower shapes for such bridges are shown in Fig. 22.

4. Development of Cross Section of Deck Structures

The cross section which the author selected in 1972 for the first long span

cable stayed bridge using precast prestressed concrete, namely, the Pasco-Kennewick Bridge (see Fig. 23) over the Columbia River in Washington State was influenced by the wind tunnel tests conducted at the NPL of Ottawa (1968). These tests were done to find the optimal aerodynamic shape for the author's design of the Burrard Inlet Bridge in Vancouver for a span length of 760 m (2492 ft).

The wind nose and the slight inclination of the bottom face gave the lowest wind coefficients and, therefore, the best provision for wind stability. However, during the design of the Parana



Fig. 21. Tower in median of Rhine Bridge in Bonn-Nord, West Germany.

Bridges in Argentina for highway plus railway traffic, it was conceived that this aerodynamic shape was useless when 400 m (1311 ft) long freight trains were on the bridge. Through dynamic tests it was learned that multi-stay cable bridges have very strong damping coefficients and do not need the same good aerodynamic shape as suspension bridges do. Therefore, the cross section could be simplified further.

The following can be concluded:

For spans up to about 150 m (492 ft) and for widths up to about 20 m (66 ft), a very simple solid concrete slab without an edge beam is the best solution (see Fig.

24). The thickness of the slab depends primarily on the transverse bending moments which can be increased towards the towers to respond to the increasing longitudinal normal forces.

Dr. Finsterwalder had proposed such slender slabs as early as 1967 for his design of the Great Belt Bridge and later also for the Pasco-Kennewick Bridge. The thickness of the slab was so small in relation to the span that the safety against buckling under high longitudinal compressive forces was subsequently questioned especially in the case of high deflections under concentrated live load

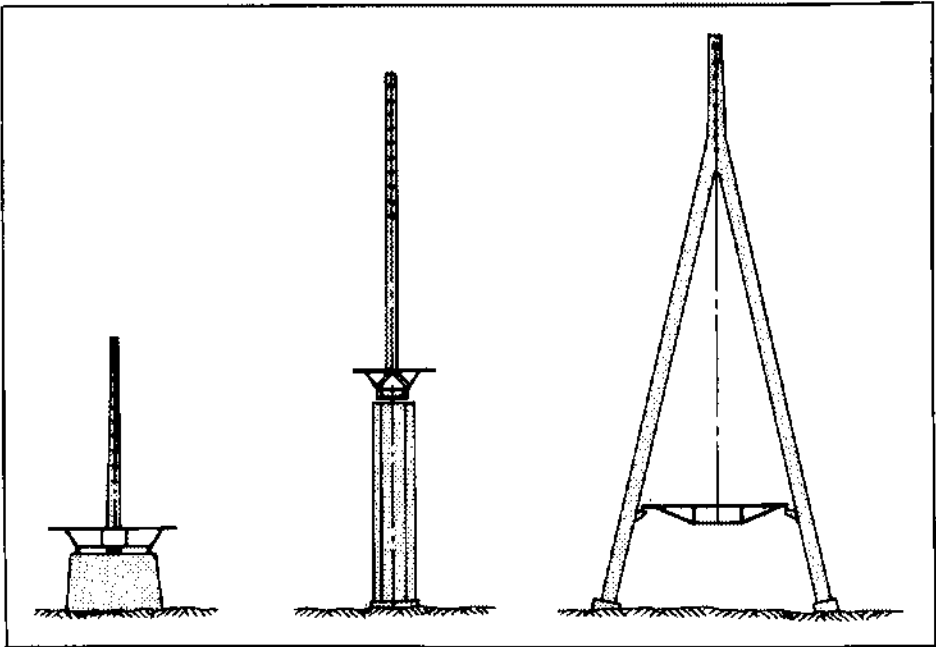

Fig. 22. Tower shapes for one plane of cables.

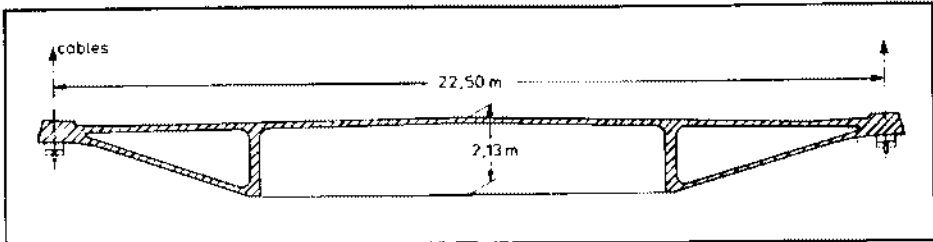

Fig. 23. Cross section of Pasco-Kennewick Bridge (1972), Washington State.

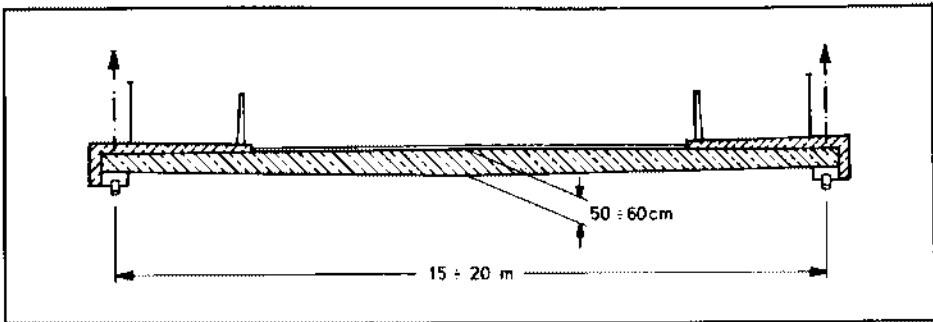

Fig. 24. Cross section with solid slab only for highway bridges with spans up to 150 m (490 ft).



Fig. 25. Bridge across the Rhine at Diepoldsau, West Germany. Span = 97 m (318 ft).

and the possibility that one cable could break in an accident.

This buckling safety was meanwhile studied by Professor Renee Walther in Lausanne, Switzerland. Second order theory calculations were checked by tests with a relatively large model. Buckling safety could now be checked reliably. It was found that a certain amount of longitudinal reinforcement is required for obtaining sufficient ductility in such thin slabs.

Professor Walther became the first engineer to build a highway bridge 15 m (49 ft) wide across the upper Rhine River in Diepoldsau with a slab only 50 cm (20 in.) thick for a main span of 97 m (318 ft) with no edge beams (see Fig. 25). He even reduced the slab thickness at the edges to 36 cm (14 in.).

For wider bridges, $B > 20$ m (66 ft), transverse T beams are, of course, more economical (see Fig. 26). The spacing of the beams should not be larger than 4 to 6

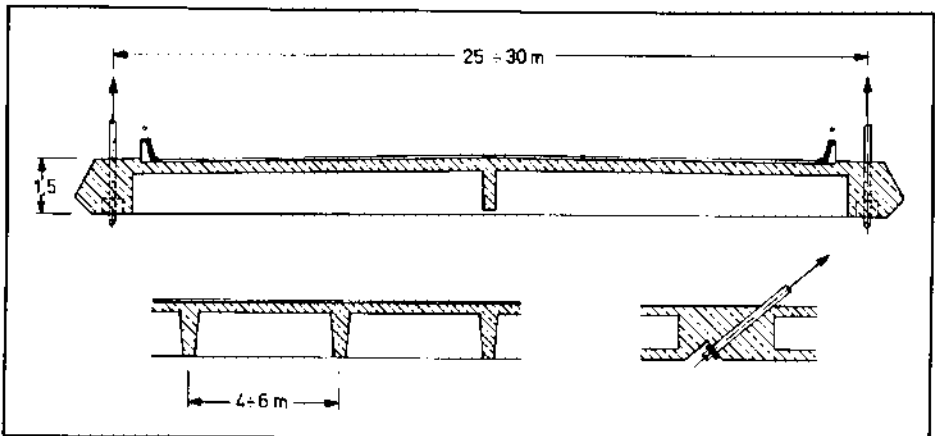

Fig. 26. Cross section with transverse beams for width greater than 20 m (66 ft) and spans up to 500 m (1640 ft).

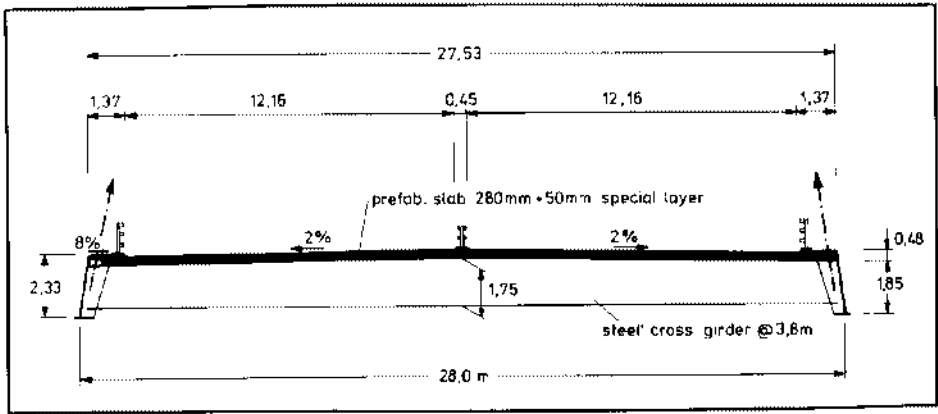

Fig. 27. Cross section of Sunshine Skyway Bridge, Florida, showing composite structure (not built).

m (13 to 20 ft) and the slab on top should always span longitudinally to make good use of the longitudinal compressive forces from the cables. The cross beams can be cast in place or prefabricated and end in a thick edge beam with a depth of not more than 1.0 to 1.5 m (3-2 to 4.9 ft), giving ample buckling safety and keeping the curvature of the deflection line under concentrated loads within allowable limits even for spans up to 500 m (1640 ft).

Such cross sections are especially suitable for composite structures, using steel cross girders between concrete edge beams which the author designed for the East Huntington Bridge. Its 274 m (898 ft) span hung up to one tower corresponds to a span of about 500 m (1639 ft) if suspended from two towers. In the proposed design (conducted by the author's consulting firm) of the Sunshine Skyway Bridge (see Fig. 27) in 1980, a 2 m (6.6 ft) deep steel edge beam was used to simplify the erection process and to allow the use of prefabricated deck slabs.

Soon thereafter, this type of section was chosen for the Annacis Bridge in Canada with a main span of 465 m (1525 ft) together with some advanced details. The project was built in 26 months which is remarkable considering the structure is 1000 m (3286 ft) long. This efficiency

shows the ease and simplicity of the erection method.

In these composite structures, the concrete must remain the main structural material. The deck slab has to carry the compressive chord forces. If for very long spans these thrust forces become too large for the normal deck slab, then its thickness should be increased towards the tower or a concrete edge beam should be added. However, the steel section should remain small in order to avoid creep problems.

If the bridge is hung up with cables in the median only, then a box girder is needed. The cross section of the Brotonne Bridge (see Fig. 28) has become a standard for this type. The required amount of torsional rigidity depends on the width of the deck and the length of the main span. Smaller cross-sectional areas of the box may often be sufficient and this would allow sections like that shown in Fig. 29, which is simpler to construct and has a smaller depth and simple cable anchorages.

For railroad bridges, especially for high speed trains, large mass is needed to get a good dynamic behavior. Therefore, the DB - German Federal Railways - carry the 40 cm, (15 in.) deep ballast over their modern bridges and prefer thick concrete

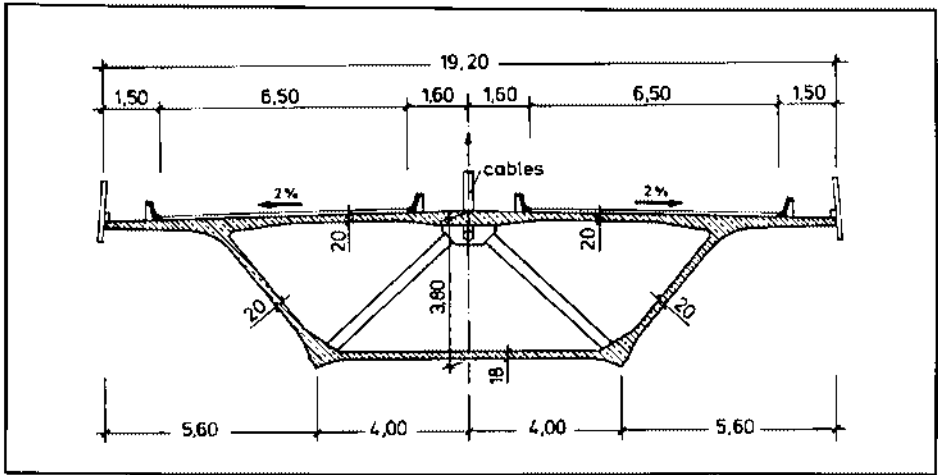

Fig. 28. Cross section of Brotonne Bridge, France, showing cables in the median.

deck slabs. with high strength cables it is not difficult and also not too costly to carry such heavy dead loads over long spans (see Fig. 30).

Edge beams 1.5 to 2.0 m (4.9 to 6.6 ft) deep should be sufficient to satisfy deflec-

tion limits if the cables are not too flat. For very long spans and severe deformation limits, a flat box section may be needed (see Fig. 31). The cables of such railroad bridges should have angles of inclination above 30 degrees.

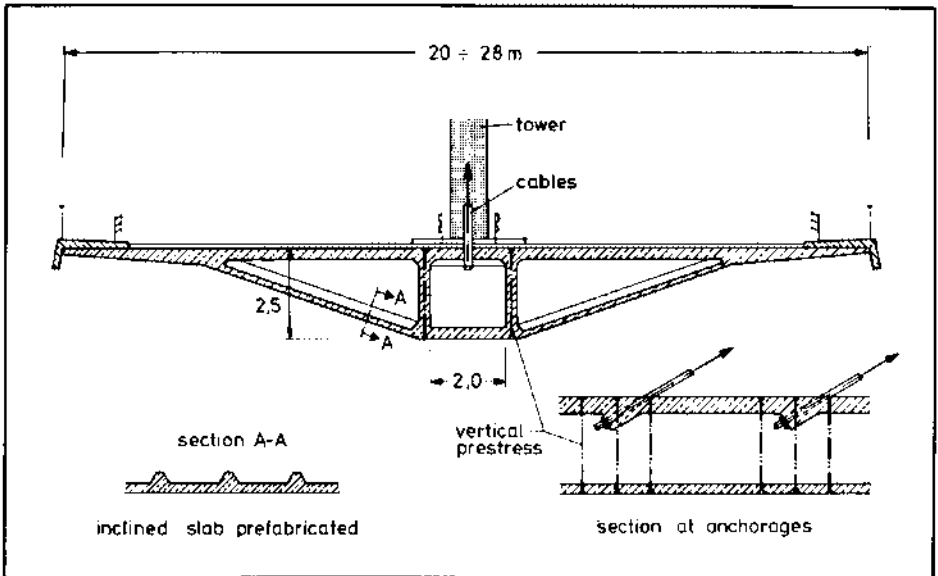

Fig. 29. Stender cross section for cables in the median with simple anchorage (Brotonne Bridge, France).

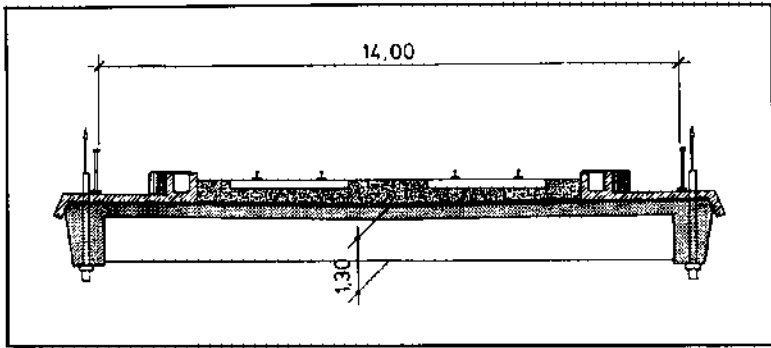

Fig. 30. Cross section of railroad bridges for spans up to 140 m (459 ft).

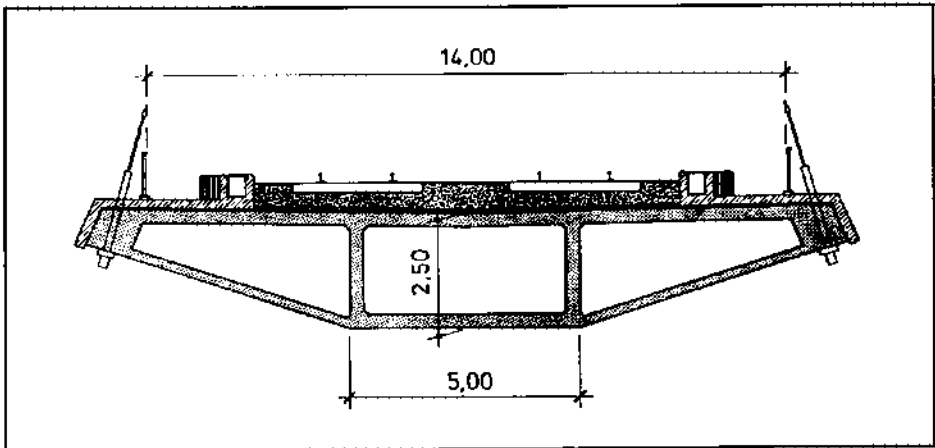

Fig. 31. Cross section of railroad bridges with spans longer than 140 m (459 ft).

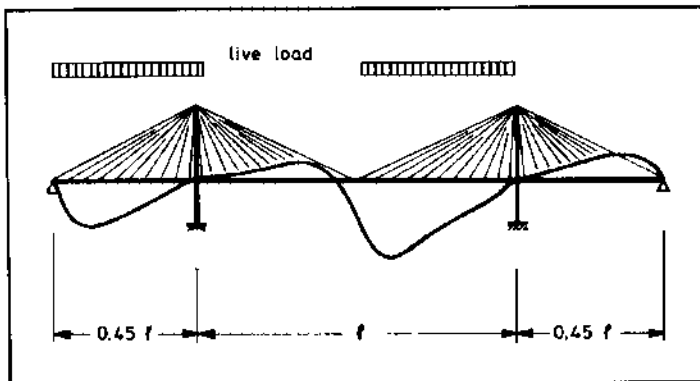

Fig. 32. Deflection line showing large angular changes at the ends of side spans.

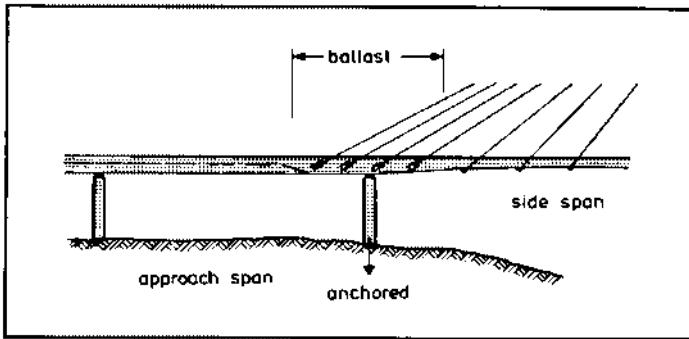

Fig. 33. Continuity to a short approach span avoids large angular changes.

5. Situation at the Ends of Cable Stayed Bridges

The sudden change from an elastic support to a stiff support at the ends of the side spans causes large bending moments and consequently a large angular change of the deflection line (see Fig. 32). These angular changes are unacceptable for railroad bridges.

The difficulties can easily be avoided if the edge beams continue with an increasing depth into a small approach span (see Fig. 33). The length and the bending stiffness of this smoothing transition span must be well designed to avoid large bending moments.

This transition span can also be used to counteract the uplift forces of the back stay cables by its weight or even by ballast concrete within its depth. It also allows the distribution of the anchorages for the back stays over a certain length behind the axis of the anchor pier.

6. Cables and Their Anchorages

6.1 Cables and Their Protection

The cables are the most important members of this system. They must be safe against fatigue, durable and well protected against corrosion - especially in an

aggressive environment. The best type of cable must be chosen and not the cheapest. It is unwise to save a few percent of steel and to later have to replace ropes with broken or corroded wires after only 8 to 12 years as was the case in the Kohlbrand and Maracaibo Bridges.

Regarding the choice of cables, test results and practical experience of more than 30 years are available. The following is the author's opinion based on experience and judgment,

There is no doubt that bundles of parallel wires or parallel long lay strands deserve preference due to their high and constant modulus of elasticity. The quality of the wires or strands must be well controlled because very different qualities are on the market. Wires with a diameter of 7 mm of St 1470/1670 N/mm² are generally used, the number of wires per cable can be 337, giving a maximum ultimate force of $P_u = 21.7$ MN or 2170 tons. Applying the rather high factor of safety of 2.2, the allowable cable force is about $P \approx 10.0$ MN or 1000 tons. It would be better to choose a lower safety factor, i.e., 1.7, but instead refer it to the 0.2 percent yield strength.

Strands are available of St 1500/1700 N/mm² with a diameter of 12.7, 15.7 and 17.8 mm (0.5, 0.6 and 0.7 in.). The biggest bundles have 91 strands, yielding to $P_u = 31.4$ MN or 14 MN allowable force.

The wires or strands are closely packed

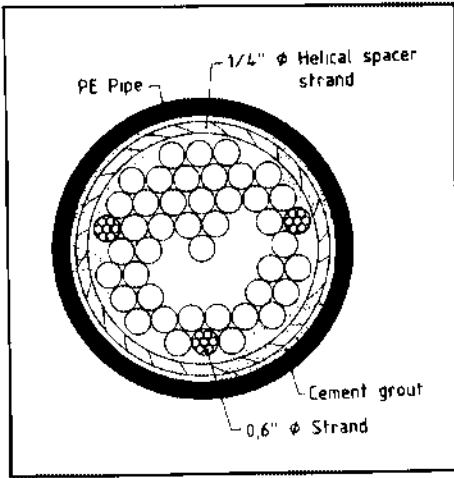

Fig. 34. Section through cable with strands.

together to minimize the diameter for the protecting pipe (see Fig. 34). These cables should only be used for wide and heavy bridges; normally smaller cables lead to a reasonable spacing and can be easier handled.

With regard to the high stress changes of back stay cables, special anchorages have been developed which avoid the damaging effect of hot metal filling in sockets which is generally used for rope anchors.

The Swiss firm BBR developed the HIAM (high amplitude) anchorage (see Fig. 35) using their button heads at the ends of the wires or strands to set a cold steel ball filling under transverse pressure inside the cone of the socket. Hereby, stress amplitudes of $\sigma = 300 \text{ N/mm}^2$

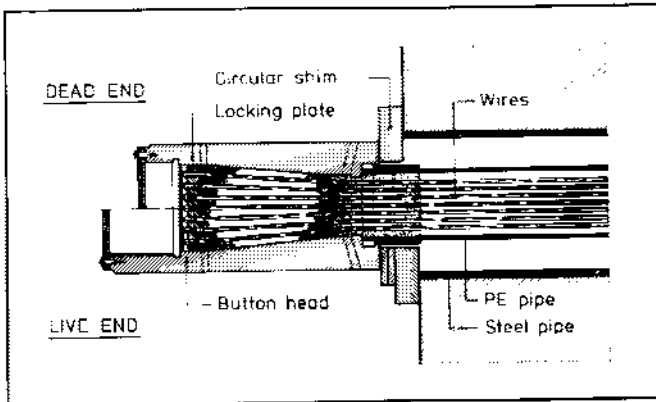

Fig. 35. HIAM anchorage of BBR.

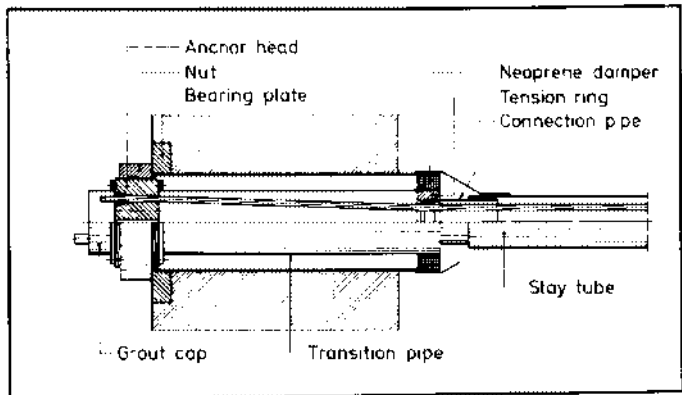

Fig. 36. VSL anchorage for strands.

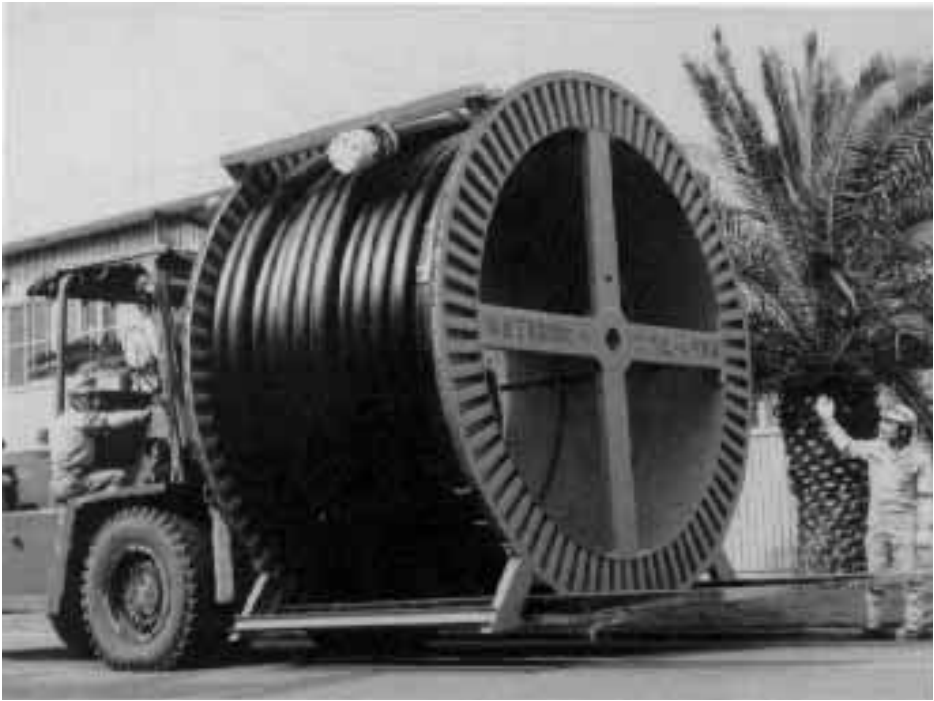

Fig. 37. Cables in polyethylene pipe on reels for transport.

(43500 psi) can be resisted with over 2 million cycles (according to the latest Swiss publications). Japanese tests confirmed these favorable values of the HIAM anchorage.

Since the number of wires in one anchorage has influence, special testing machines had to be developed to test these big bundles at full size with pulsating forces up to 700 t (772 tons). The Swiss firm VSL has developed an anchorage (see Fig. 36) holding up to 91 strands with wedges, yielding a fatigue amplitude of $\Delta\sigma = 200 \text{ N/mm}^2$ (290000 psi). The Freyssinet group and Dywidag have anchorages for strands with similar qualities.

For corrosion protection, a polyethylene (PE) pipe around the wire bundle is the optimal solution. The PE is made resistant against ultraviolet rays by adding 2.5 percent of carbon black.

More than 40 years of experience has

shown that this material is durable in tropical regions as well as in polluted air of an industrial environment. The few cases in which PE pipes were damaged by cracking have been traced to causes which can safely be avoided. Of course, quality control, sound judgment or the retention of a consultant are necessary.

The PE pipe can be pulled over the bundle or applied by extrusion. It should be at least 7 mm (0.275 in.) thick. PE is impermeable to vapor and gives full corrosion protection. Therefore, the material to fill the voids inside the pipe in order to take moisture and oxygen out, need not have anti-corrosive qualities. Usually, cement grout is injected after the cable is under dead load stresses because cement grout is the cheapest filling material and also has good corrosion protection characteristics. However, this injection procedure is not always liked on the site. In the future, the

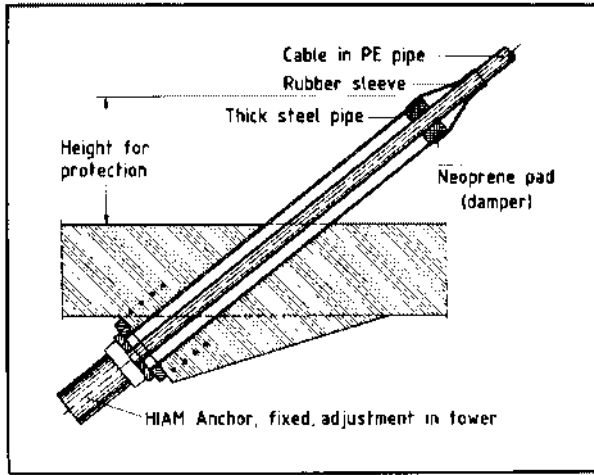

Fig. 38. Standard cable anchorage at the deck.

cables will most likely be filled in the factory with a rubberlike deformable material.

The PE pipe must be tightly and reliably fixed to the anchor socket so that the cable

can be finished in the factory, rolled on reels (see Fig. 37) for shipping, and easily handled at the bridge site. These advantages cannot be obtained with steel pipes around the bundle which must in addition get painted for protection.

The only disadvantage of the PE pipe is its black color, which detracts from the good appearance of the bridge in its environment. Therefore, the cables of some bridges have been wrapped with a tape of a brighter color like ivory or wine red. The tapes of PVC used at the Pasco-Kennewick Bridge deteriorated after about 6 years. Later, Tedlar tapes of polyvinyl fluoride were used for which a 20 year life is expected. This wrapping does not cost much but it embellishes the bridge as can be seen from the color photos of the East Huntington Bridge.⁵

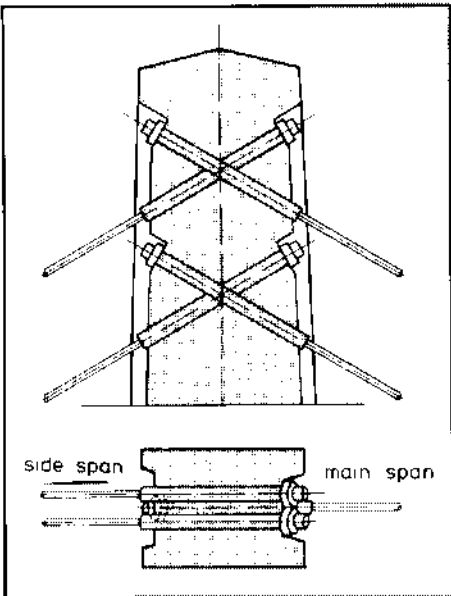

Fig. 39. Crossing of cable anchorages in tower head.

6.2 Anchorages

The anchorages must be designed to allow adjustment of length and replacing a cable damaged by an accident without interrupting the traffic. They must further be designed to prevent bending stresses in the wires or strands at the socket due to change of sag or due to slight oscillations. The anchorage should further comprise

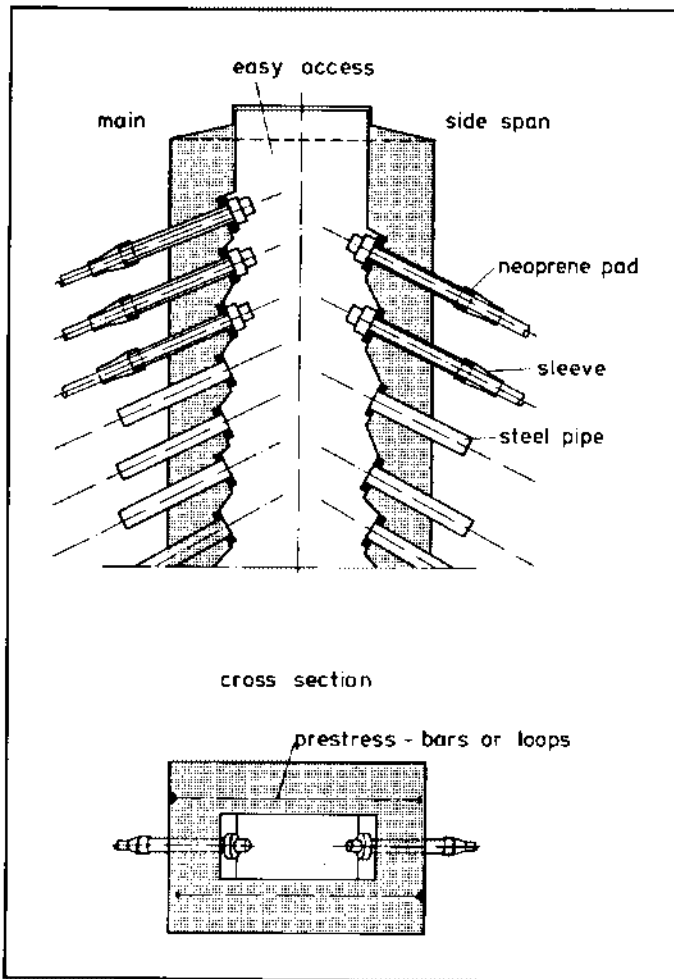

Fig. 40. Cable anchorage inside tower with box section.

dampers to prevent resonance oscillations of the cables caused by wind eddies (following the Von Kaman effect).

The anchorage at the deck structure which the author designed for the Pasco-Kennewick Bridge in 1972 has meanwhile become the accepted solution (see Fig. 38). A strong steel pipe is encased in the concrete with the correct angle of inclination. The diameter is large enough to thread the anchor socket of the cable through the pipe and place shims or turn the anchor nut on, which allows

length adjustment. The steel pipe extends about 1.2 m (3.9 ft) above the road level to protect the cable against aberrant vehicles. On its top there is a thick soft neoprene pad, which acts as a damper and stops flexural movements of the cable. The top is sealed with a rubber sleeve.

At the tower head, cables running over a saddle like in a suspension bridge should be avoided because their replacement would be rather difficult. It is preferable to anchor the cable at each side individually and to design devices to carry the hor-

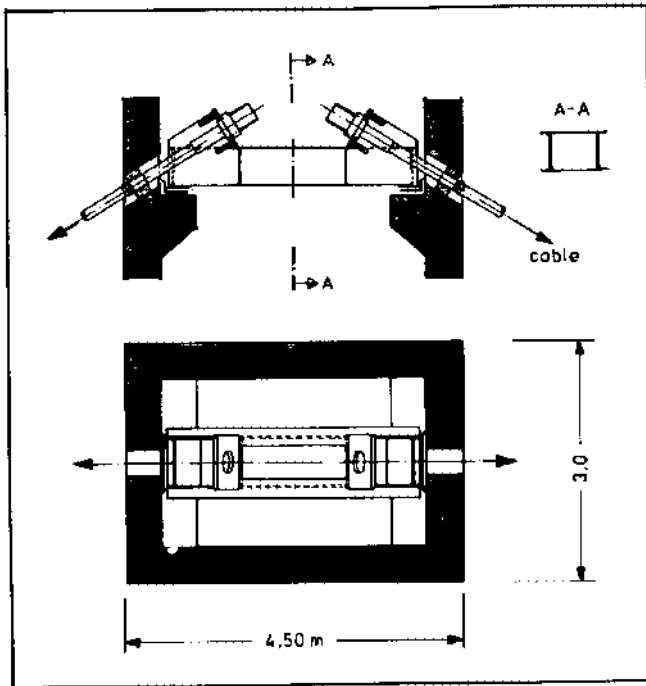

Fig. 41. Cable anchorage by means of a steel beam inside concrete tower.

horizontal component of the cable forces through the tower. The simplest solution is shown in Fig. 39 in which the cables cross each other, again in steel pipes. This is easy if there are single cables towards the main span and twin cables for the short side span.

Since the concrete towers usually have shafts with a box section, it is practical to arrange the anchorages inside this box section as shown in Fig. 40. The horizontal component of the cables is taken up in the longitudinal box walls by prestressed bus. All anchorages are easily accessible. There must be sufficient space for applying a jack to adjust the cable length, which can be done here much easier than at the deck anchorages. At the end of the steel pipe there is again the neoprene pad and the sleeve.

For the Annacis Bridge, the prestressing was avoided by placing short steel beams

inside the box section which take the horizontal component of the cable forces (see Fig. 41). These beams must be well anchored for unbalanced horizontal forces during erection or for the case in which a cable must be exchanged. The tower box must be wide enough to allow access and handling of the jacks. All these solutions make the erection very simple if prefabricated flexible cables with slender anchor sockets are used.

7. Dynamic Behavior and Aerodynamic Stability

The cable stayed bridges with concrete decks and highly stressed cables [$E_{eff} > 180000 \text{ N/mm}^2$ (26,100,000 psi)] have a very favorable dynamic behavior. The deflections under live load are extremely small because the effective depth of the large cantilever truss formed by the cables

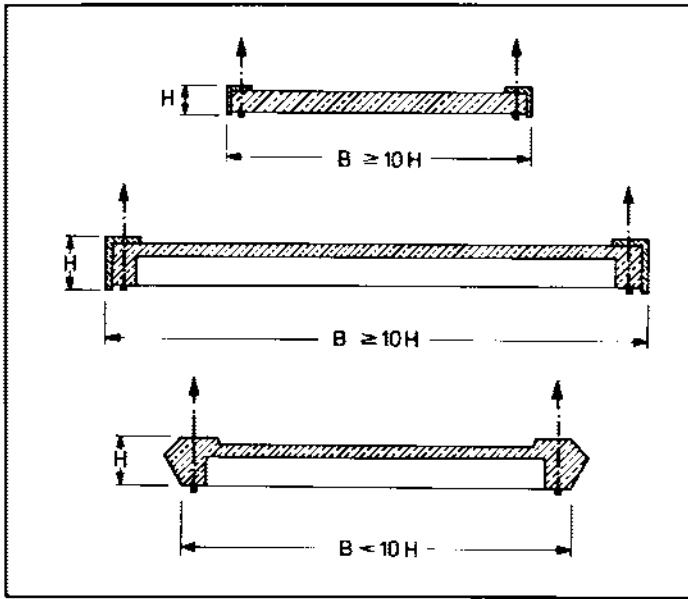

Fig. 42. Geometrical relations for obtaining wind stability with cables at beam edges.

is much larger than for beam girders.

Most important is the fact that the increase of amplitudes due to resonance oscillation is prevented by system damping caused by the interference of the many cables. This is an advantage of the multi-cable system. Measurements at the Tjörn Bridge in Sweden showed that the damping increases with increasing amplitudes and the logarithmic decrement gets well above 0. 10.

This damping is very favorable for the wind stability. Current theories which calculate critical wind speeds do not adequately represent the actual behavior and have only limited validity. The same is true for wind tunnel tests with sectional models in which only a constant damping factor is applied. More tests should be made of actual bridges to improve our theories based on observed facts.

From our present knowledge we can say that there is no danger by wind with concrete bridges hung up with cables in two planes along the edges, if the following

geometrical relations are observed (see Fig. 42):

1. $B \geq 10H$
2. For $B < 10H$, a wind nose should be added.
3. $B \geq 1/30 L$. This means that the width of the bridge should not be too small in relation to the main span. If this ratio gets smaller, then A-shaped towers and wind shaping of the cross section must be used.

The A-shaped tower gives a triangular shape of the cable planes and the deck, which increases the torsional rigidity.

The author was a consultant in the design of the bridge at Posadas Encarnacion, Argentina (see Fig. 43), which has to be safe against tornados with their enormous uplift forces. A rather heavy box girder and A-shaped towers were selected to get the required safety. H. Cabjolsky reported on this bridge at the FIP Congress (1986) in New Delhi.

Bridges hung up with cables in one plane along the center line have almost no

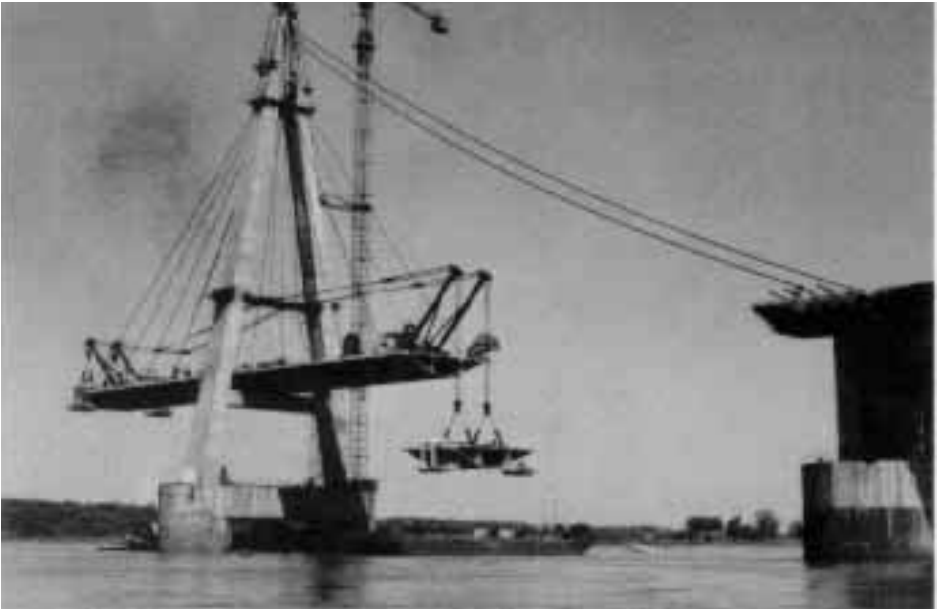

Fig. 43. Erection of Posadas Encarnacion Bridge, Argentina.

damping for torsional oscillations. Caution is recommended because this case has not been sufficiently studied.

Caution must also be taken for some erection stages mainly during free cantilevering on both sides of the towers especially if the cantilever length becomes larger than $20 B$. Unsymmetrical and inclined wind forces can cause trouble. Temporary wind noses or ropes to submerged anchor blocks can prevent dangerous oscillations.

8. Prestressing of Cable Stayed Bridges

For bridges with cables along both edges longitudinal prestressing of the deck structure is needed only over a certain length in the middle of the main span, if towers stand on both sides. The horizontal thrust forces of the cables are zero in $l/2$; there may even be tension due to restraint forces caused by bearings and unsymmetrical live load. Further, there

are bending moments due to concentrated live load. In slabs as shown in Fig. 24, the longitudinal tendons can be distributed over the width of the bridge with some concentration near the edges. In cross sections like Fig. 26, all tendons can be placed in the edge beams.

The longitudinal thrust in the deck due to the cable forces increases towards the towers, causing so much compression that no additional prestressing is needed there. However, towards the ends of the side spans, this thrust decreases and the bending moments increase; consequently, longitudinal prestressing is needed. Since the bending moments are mainly caused by local live load with maxima conditions rarely happening, partial prestressing will be sufficient.

Transverse prestressing is desirable for widths between 10 to 15 m (33 to 49 ft) mainly at the ends of the side spans, where the spreading out of the cable forces over the width of the deck causes transverse tension. For wider bridges, transverse prestressing should generally

be used against transverse bending and transverse normal forces caused by the cable forces. The degree of prestressing may be chosen for no tension in the concrete due to dead load plus 20 to 40 percent live load depending upon the weights of national live load specifications which vary considerably throughout the world.

For bridges hung up by one row of cables along the centerline with a box girder, more longitudinal prestressing is needed, because the large bending stiffness of these girders cause large positive and negative bending moments. The tendons may be placed in the top and bottom slabs. Transverse prestressing is needed for the transverse bending moments and to counteract torsional stresses which can be rather large towards the towers. A high degree of prestressing is suggested here, because the torsional rigidity gets almost lost, as soon as cracks due to tensile stresses occur (see Chapter 7 in Ref. 4).

If segmental construction with prefabricated elements is chosen with no longitudinal reinforcement across the joints, then a rather high degree of prestressing is imperative in the longitudinal direction. This prestressing prevents partial opening of these joints due to differential shrinkage and creep which is caused by frequent high temperature of the deck slab (sunshine) and often by a different thickness of the members (web thicker than bottom slab, etc.). The high degree of prestressing is especially needed if unbonded external tendons are used and no reinforcement crosses the joints, in order to get the required safety for the ultimate limit state.

9. Construction Methods

The common construction method for multi-stay cable bridges is free cantilevering from the tower towards both sides.

The final cables are used to support one segment after the other. Since full symmetry of loadings can usually not be secured, the tower must be stiffened under the deck

by struts or by retaining cables from the tower head to suitable anchor points.

For cross sections like those shown in Figs. 24 and 26, casting the segments in place is preferred because the joints can be secured by overlapping longitudinal reinforcement which helps to prevent cracks due to unforeseen restraint forces. Such reinforcement also aids in securing the required safety for the ultimate load condition. A part of the edge or edge beam with the anchor steel pipe in the correct position can be prefabricated and fixed to the cantilevering steel girder carrying the forms. The construction head can be sheltered against the weather.

For bridges with box girders, prefabricated segments can be used with match cast joints but using a paste in the joint which compensates for differential shortening during the curing and hardening period. Prefabricated segments can also be mounted, leaving a gap for overlapping longitudinal reinforcement by means of steel hinges on the webs, which allow adjustment for the correct positioning of the segment. This has been done successfully at the Parana Bridge in Posadas Encarnacion (see Fig. 43).

Bridges with a deck of composite beams allow the simplest and quickest erection. The grid of steel cross girders and light steel edge girders, including the cable anchors, are installed with light derricks and then the prefabricated concrete slabs are placed, leaving gaps for overlapping reinforcement and shear connectors which are closed by cast-in-place concrete. The Annacis Bridge in Vancouver, British Columbia, is a good example.

The cables in PE pipes have recently been pulled up to the towers from the reels standing on the deck or even from boats without any auxiliary cables using only curved saddles with rollers in order to prevent excessive bending. The hauling equipment must be strong enough to pull the cable socket into the deck anchor. The last stretch is done by a hydraulic jack which can resist the full dead load cable force.

During the last ten years, construction methods have shown major progress towards simplification and reducing erection equipment. The construction must, however, be well planned using step by step calculations for the alignment, forces, exact lengths and angles considering temperature and creep influences, which depend on seasonal, climatic and even daily conditions. The old rule must be observed that all measurements should be made early in the morning before the sun rises. Special expertise is still needed, which is rather rare, since most universities do not teach such essentials for practical work.

10. Closing Remarks

Due to limited space, the author had to omit several subjects which are important for a modern design of a cable stayed bridge. For example, in multispan bridges, the best arrangement of bearings and joints or provisions against seismic damage are not covered. Also, codes of practice and project specifications, which often are not up to date with respect to the latest research and experience, are not mentioned.

Nevertheless, the author hopes that he has demonstrated how simple the cross sections and the details of these bridges can be if our collective experience and

knowledge gained during the past thirty years is well exploited. The author is confident that such cable stayed bridges of prestressed concrete will have a wide field of application in the future in countries throughout the world to serve the needs of human society.

But in our work, let us always search for good quality, durability, ease of inspection and maintenance and especially let us not forget the aesthetics of a structure as it affects the environment.

REFERENCES

1. Leonhardt, F., and Zellner, W., "Vergleiche zwischen Hänge- und Schrägkabelbrücken für Spannweiten über 600 m", Band 32 der IVBH-Abhandlungen, Zurich, 1972.
2. Leonhardt, F., and Zellner, W., "Cable Stayed Bridges," IABSE Surveys, S 13/80, Zurich, 1980.
3. Saul, R., Svensson, H., Andes H. P., and Selchow, H. J., "Die Sunshine Skyway Brücke in Florida, USA," Bautechnik, Hefte 7 - 9, Berlin, 1984.
4. Leonhardt, F., Vorlesungen über Massivbau, Teil 4, Springer Verlag, Berlin, 1984.
5. Grant, A., "Design and Construction of the East Huntington Bridge," PCI JOURNAL, V. 32, No. 1, January-February, 1987, pp. 20-29.



R E G I E R U N G S B A U M E I S T E R
B E R A T E N D E R I N G E N I E U R
V B I V D I D A I M A S C E

B R Ü C K E N U N D H O C H B A U
S T A H L S T A H L B E T O N
H O L Z S P A N N B E T O N

7 0 0 0 S T U T T G A R T N . L E N Z H A L D E 1 6
T E L E F O N : (0 7 1 1) 2 5 0 6 0
T E L E G R A M M E : F R I L E O
T E L E X : S T U T T G A R T 7 2 2 4 6 1

This report is reprinted from the copyrighted
JOURNAL of the Prestressed Concrete Institute,
V. 32, No. 5, September-October 1987.

prestressed concrete institute

175 W. JACKSON BOULEVARD
CHICAGO, ILLINOIS 60604
312-786-0300